

Contents of Love Seat Pull Out Body box :

*Bi-Fold Arms and Hardware Pack are packed in a separate box.

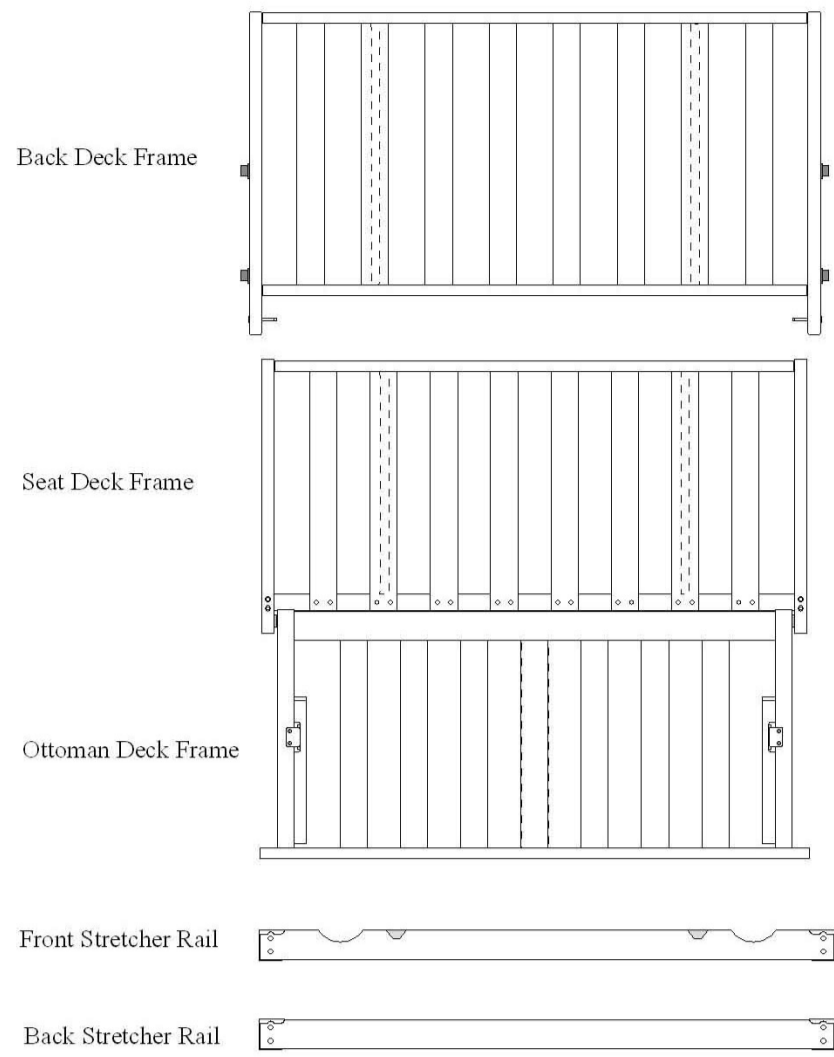

Love Seat Pull Out Body

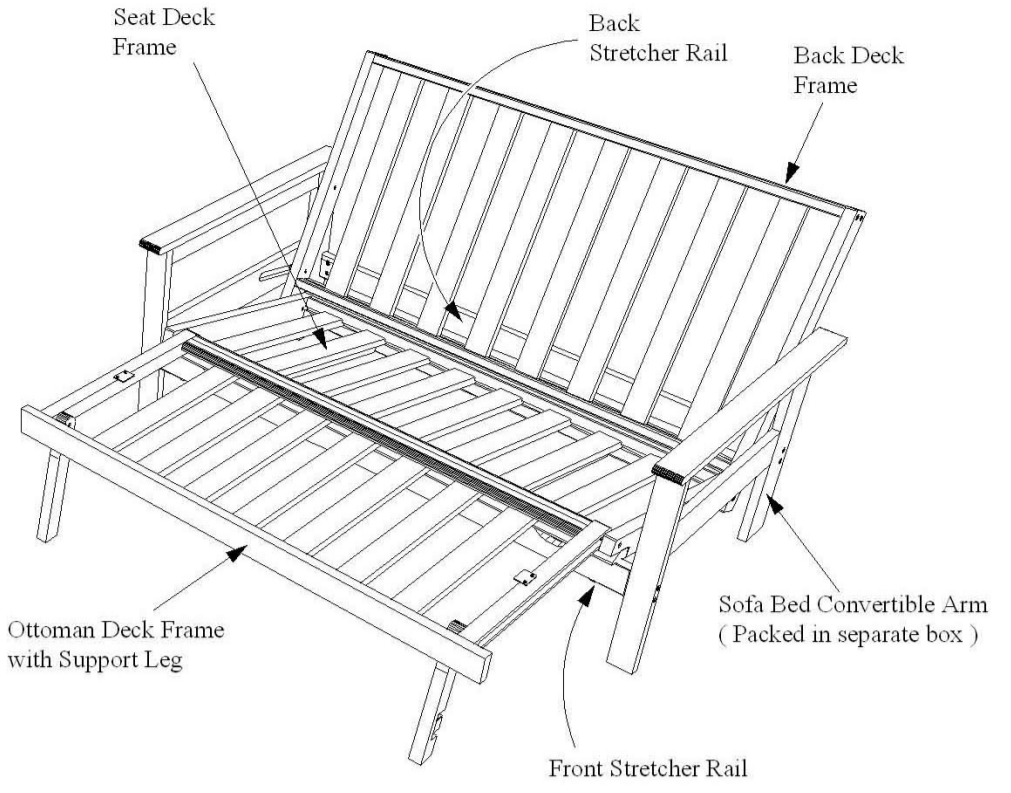

Important notes

Full (double) size is shown here. Other sizes differ only in overall size. Your Arm style may vary from the one pictured in this assembly instruction. Assembly procedures are still the same for all Arms unless stated in the Arm parts list.

Hardware is inside the Arm box.

PART A

Fig. 1

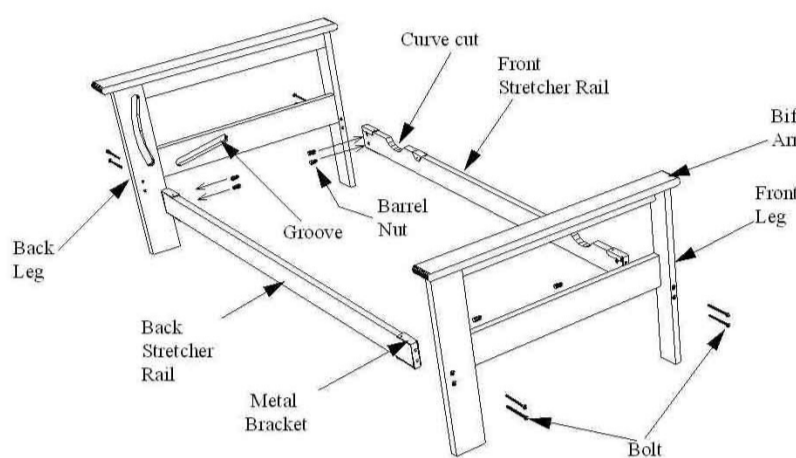
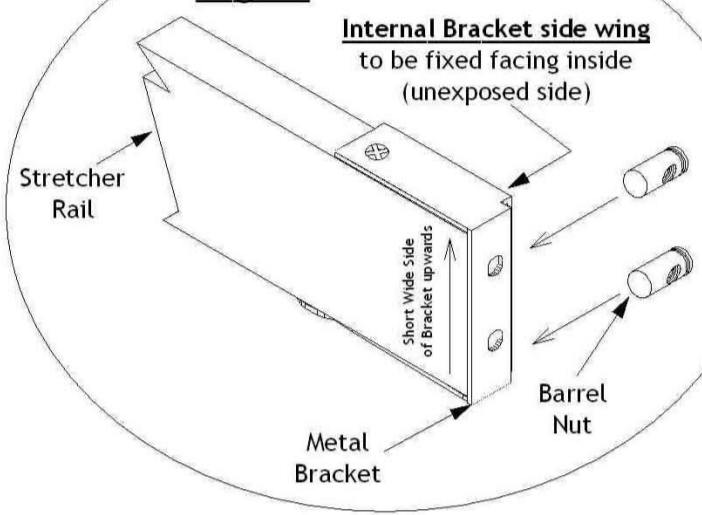

Fig. 2



Step 1: Unpack the Bi-Fold Arms and take note that the metal brackets attached to the both ends of Stretcher Rails have 2 different top edges.

Step 2: Align the Stretcher Rails to the Arms (Fig. 1). Make sure that the short, wide side of the metal brackets face upwards while the flat trimmed edges face the exposed side (Fig. 2).

Bolt and Barrel Nut assembly are illustrated in figure 3. **DO NOT TIGHTEN BOLTS UNTIL END OF PART B!**

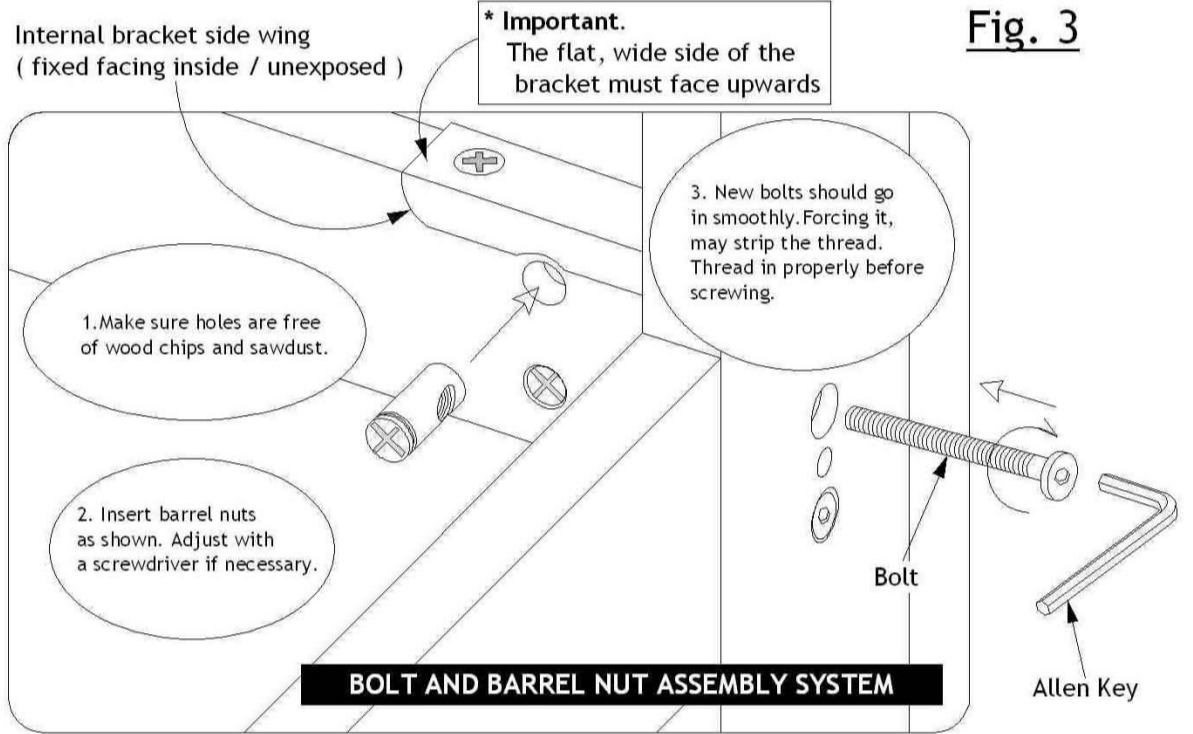
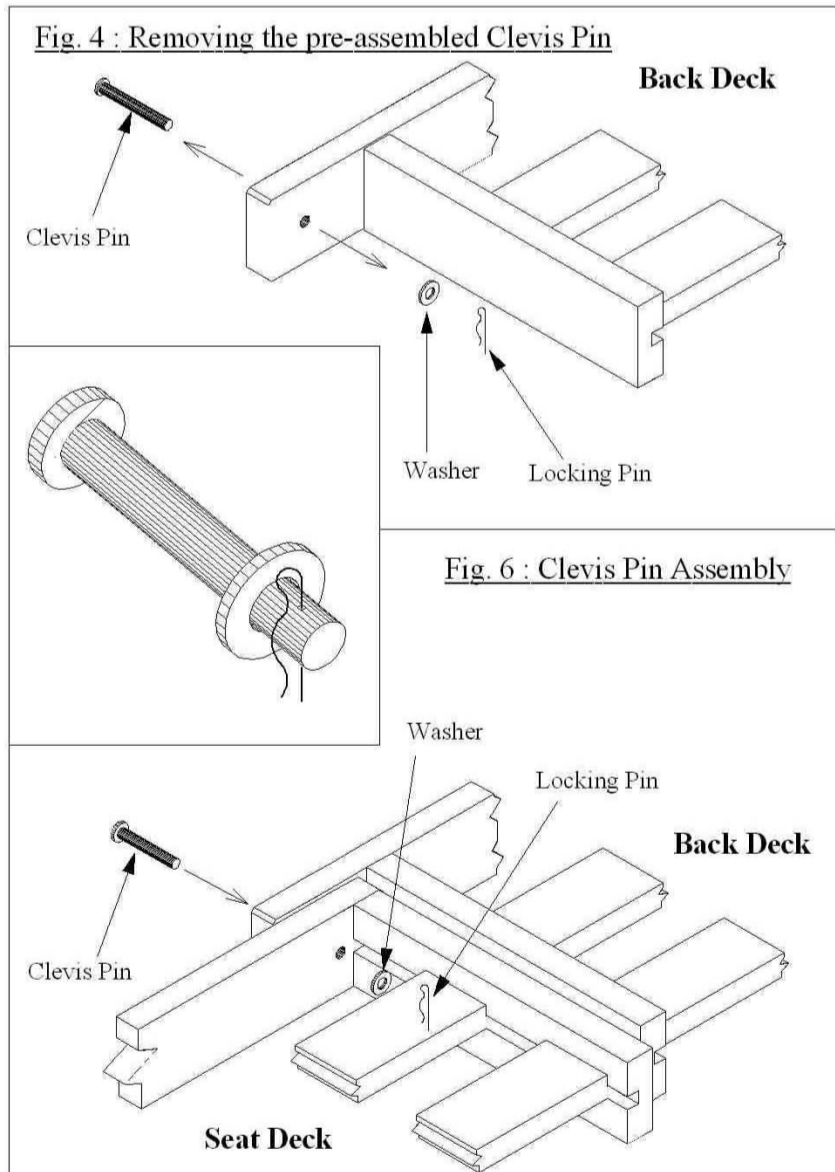

Fig. 3

Step 3 : Fig. 4 : Removing pre-assembled the Clevis Pin

Remove the pre-assembled Clevis Pin from both side of the Back Deck as per the illustration in Fig. 4.



PART B

Step 4:

After removing the Clevis Pins, lay the Back Deck flat and have someone hold it in position. Align the Clevis Pin hole on both side of Decks in Fig. 5.

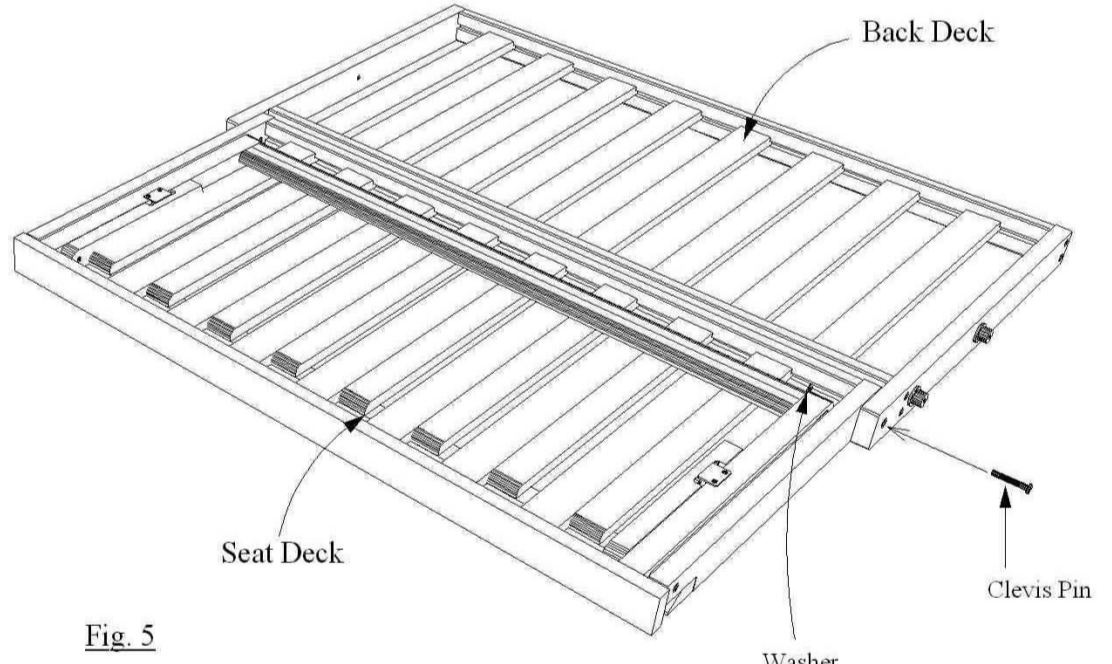

Fig. 5

Step 5:

Level the Seat Deck into position and then reinstall the Clevis Pins as shown in Fig. 6.

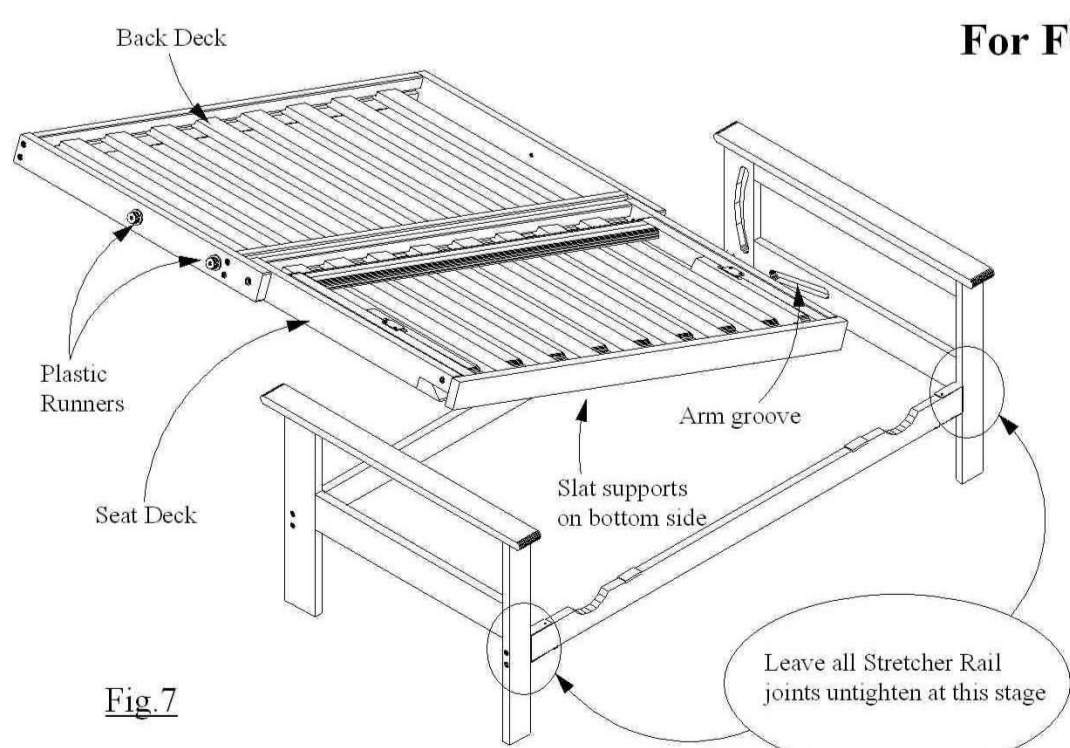

Fig. 7

Step 6 (Fig. 7)

This step can be tricky and would require two or more people. Place the assembled Decks between the Arms. Ease in one end of the Plastic Runners into the grooves first and then gently lower and position the other end and fit the Plastic Runners into the grooves of the Arms. Make sure that the rear side (with slat supports) is facing downwards.

* Be careful : The Plastic Runners can damage the Arm Rest if handled roughly.

For FO2/FB2/FC2 style Groove

The Groove on your Arm will look like this...

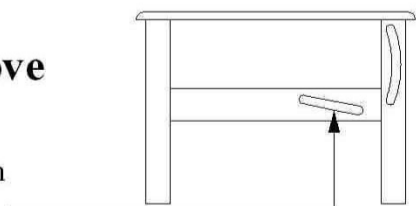

Step 7 (Fig.8)

Once the Decks are in place, tighten all the Bolts and secure the Love Seat Pull Out Body in place.

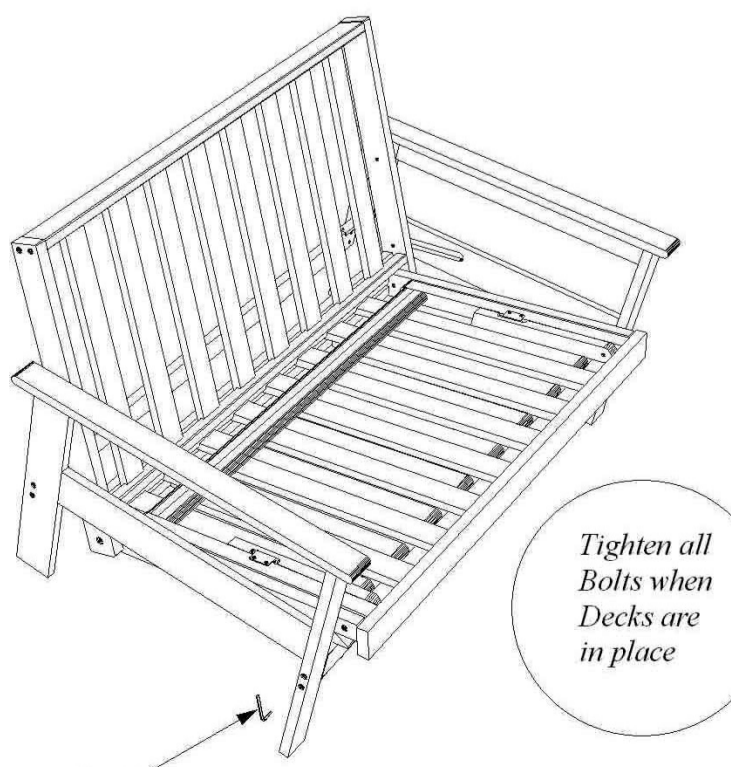

Fig. 8

Allen Key