

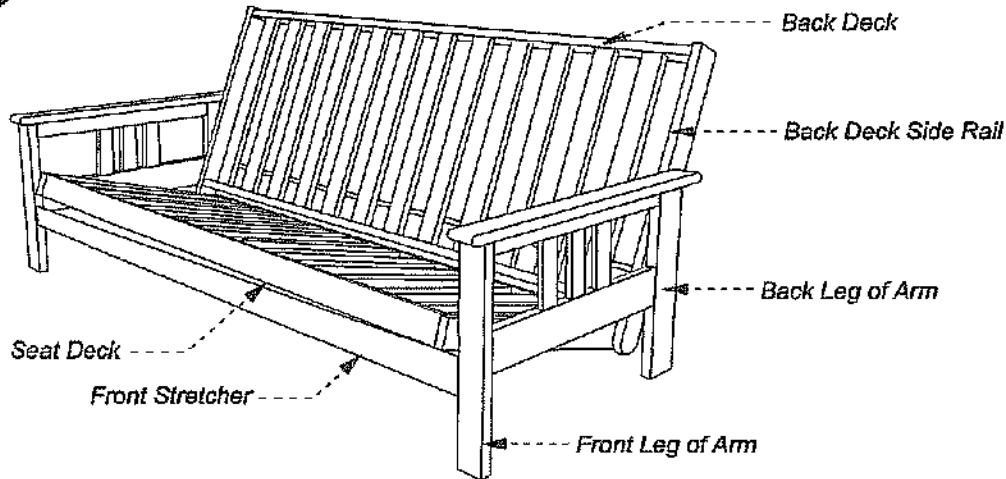

# BIFOLD FUTON FRAME SEDONA

Instructions apply to all sizes:  
Chair • Full / Double  
Love seat • Queen

B.03



## 1A Parts in this box.

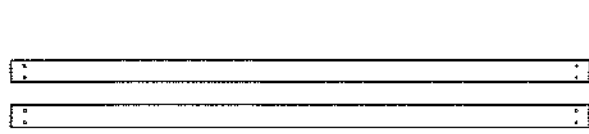

Stretchers x 2  
( Full size illustrated)



Side Rails x 2

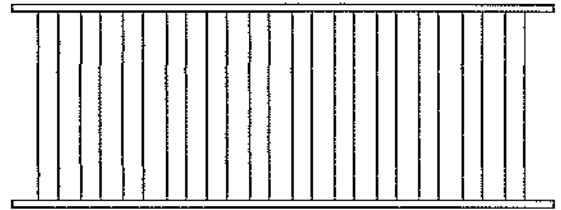

Back Deck x 1  
( Full size illustrated)

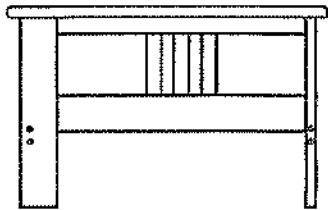

Outside View

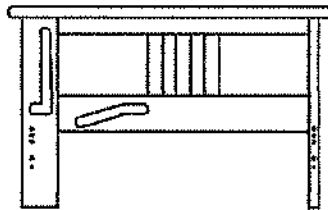

Inside View

Arms x 2

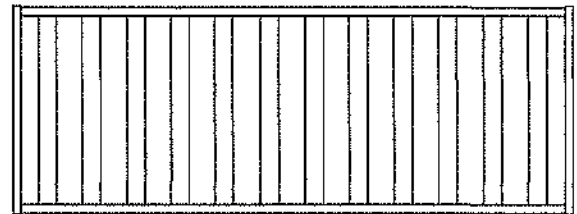

Seat Deck x 1  
( Full size illustrated)

## 1B Hardware in this box



Barrel nuts  
x 12 pcs



Washers  
x 2 pcs

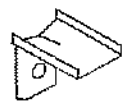

Stretcher Brackets  
x 4 pcs



Wood Buttons  
x10pcs



16mm Bolts x 4 pcs  
For the Stretcher Bracket.

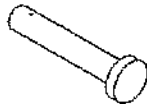

Clepis Pins  
x 2 pcs



Wooden Dowels  
x 4 pcs

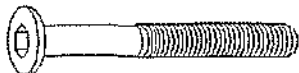

60mm Bolts x 8 pcs  
For the Side Rails and Back Leg.



Locking Pins  
x 2 pcs



Allen Key  
x 1 pcs

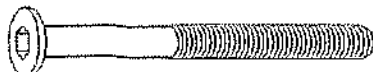

100mm Bolts x 4 pcs  
For the Front Leg.

**Queen size parts.**

Queen Legs x 2 pcs

Hardware to fix the Queen legs

50mm Bolts x 2 pcs



## 2A Prepare Arms for Assembly.

**NOTE:** The hardware for these steps is included with the Arms. Some Arms may not have these features, so just skip these steps.

### Fasten Stretcher Brackets to Arm.

- Insert the Stretcher Bracket Cleat into the hole provided.
- IMPORTANT:** Don't fully tighten Bracket until Stretchers are all in place for easy alignment.
- Each arm requires two brackets, front and back.

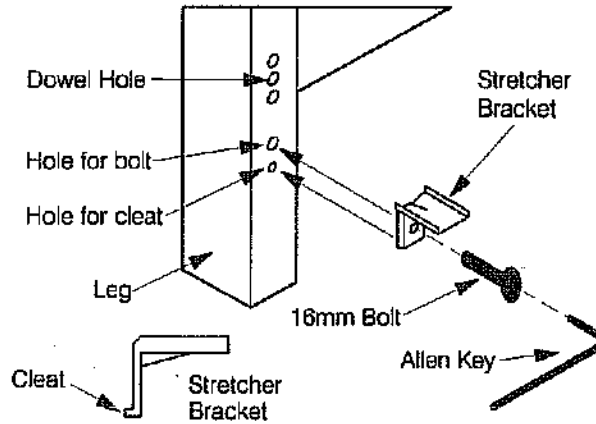

### Fit Wooden Dowels.

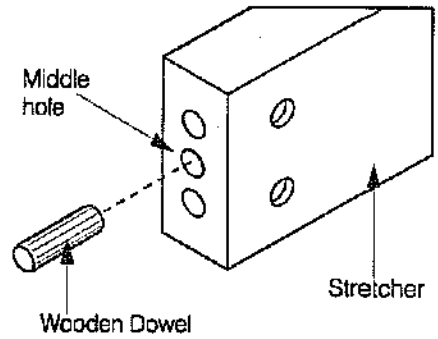

Tap dowels all the way into the middle hole, at each end of the Stretchers

## 2B Attach Arms to Stretchers.

Using Bolts and Barrel Nuts provided with the Arms, attach the Arms **LOOSELY** to the Stretchers as shown. It is important that these bolts are left loose!

*Your arm style may vary.*

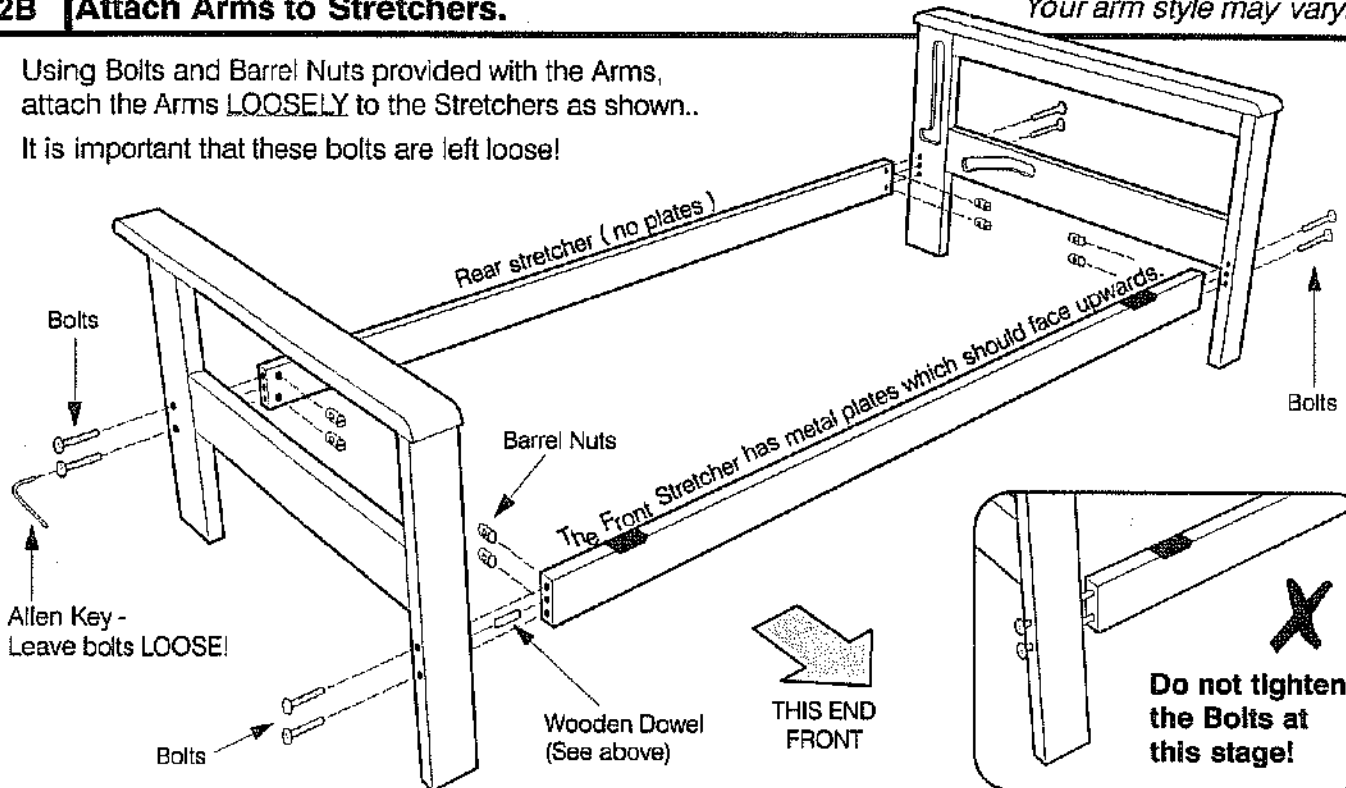

### BOLT AND BARREL NUT ASSEMBLY SYSTEM

- ✓ Insert Barrel Nuts as shown using a screwdriver. This will help you position the Nut in line with the Bolt.
- ✓ Do not force the Bolt as you may strip the thread. Be sure the thread is properly started.

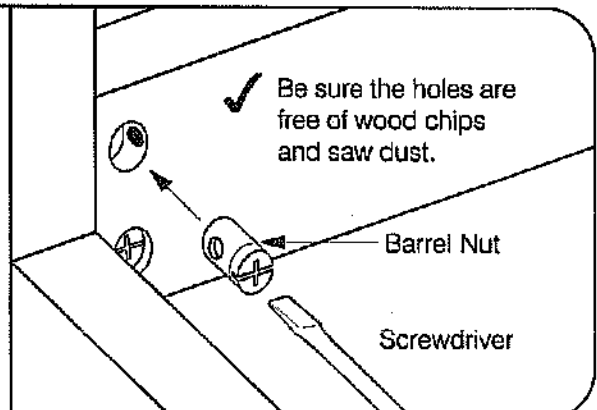
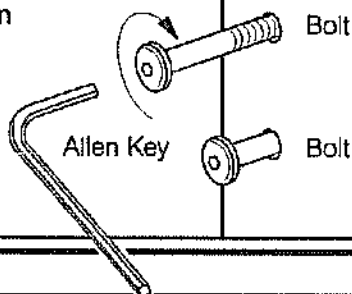

### 3A Attach the Back Side Rails to the Back Deck.

Using the Bolts and Barrel Nuts packed to attach the Side Rails to the Back Deck. Fit Wood Buttons into Bolt Holes as shown below.

- ✓ The Back Side Rails have a Rounded end, which assembles to the bottom Long Rail.

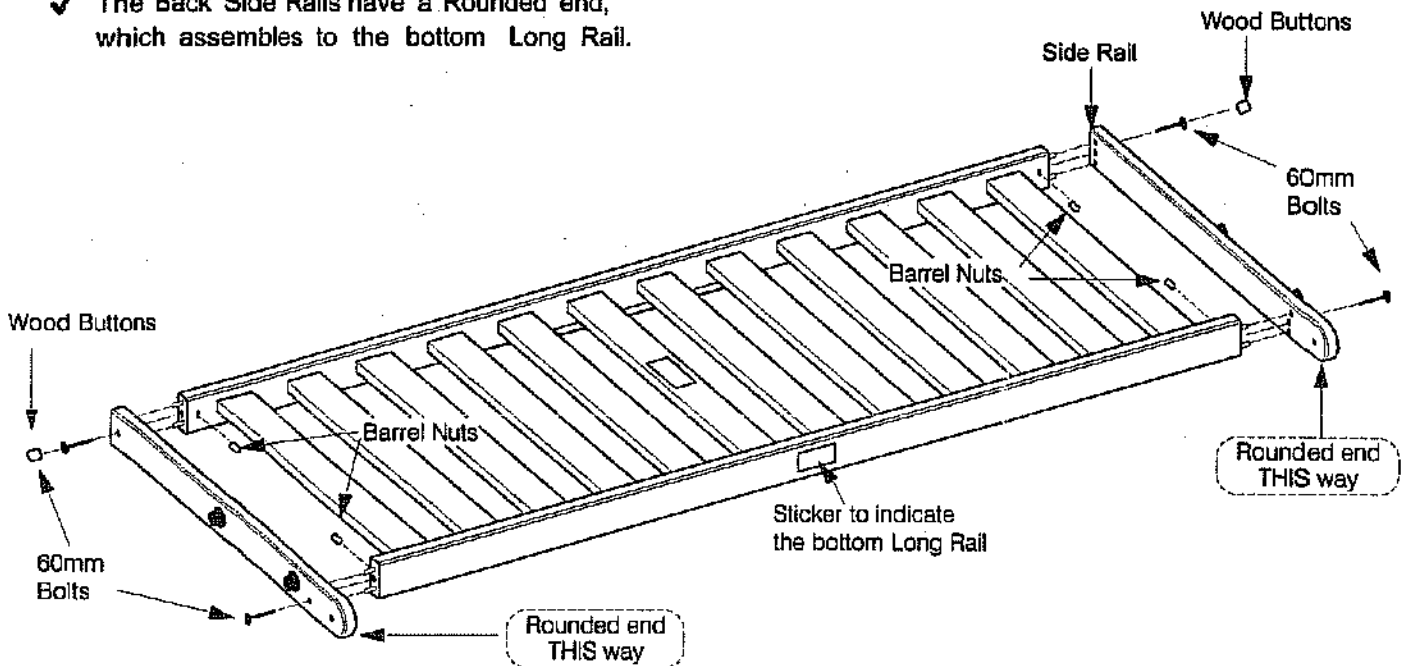

After tightening all the Bolts on Back Deck, push fit or lightly tap the Wood Buttons into the holes as shown.

- ✓ The Back Side Rails have a Rounded end, which assembles to the bottom Long Rail.

### 3B Seat Deck: No assembly required

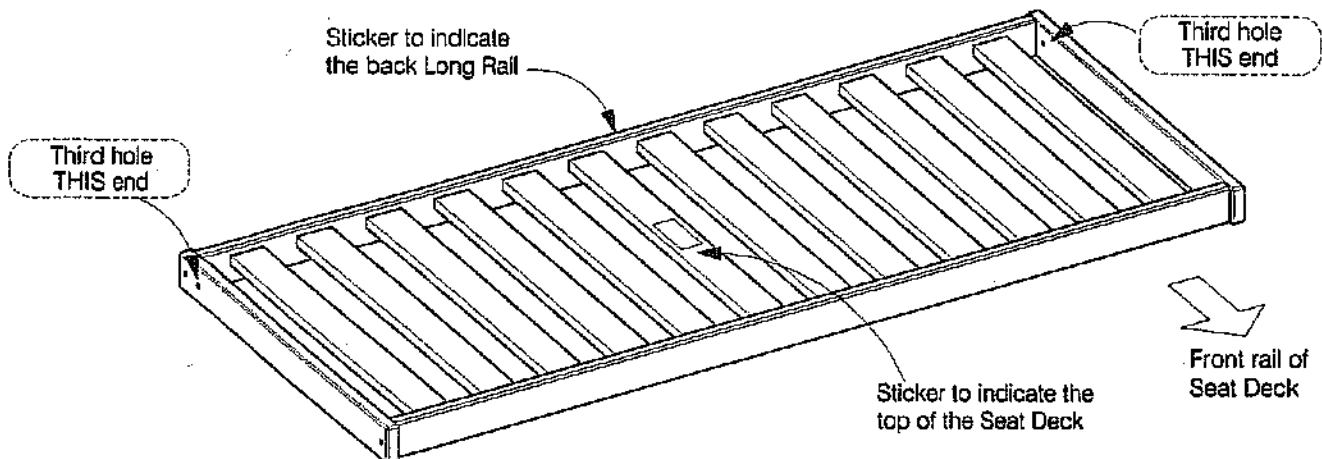

- ✓ The Seat Deck is already assembled, and no assembly is required.

#### Helpful Tip:

Mattress will sit on this surface (Surface with Sticker Indication)

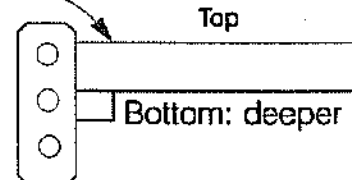

#### 4A Fit Back Deck into Position.

A. Insert the Back Deck lying flat. Insert one end first, then gently lower the other end into position.

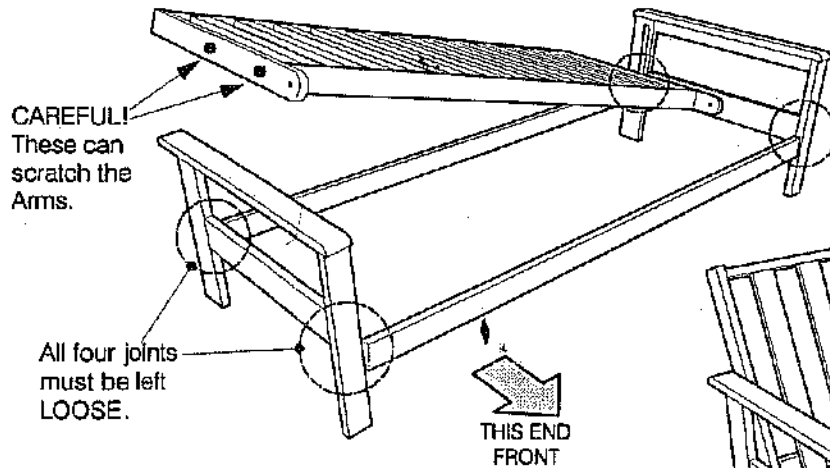

*Your arm style may vary*

- ✓ This step can be tricky - it is best done with two people
- ✓ Remember that the Bolts on the Arm should be LOOSE.
- ✗ Be careful not to scratch the Arms with the Plastic Runners when you lower the ends of the Back Deck.

B. When you have the Back Deck fitted lying flat, tighten all the Bolts. From the back, lift the Back Deck to upright as illustrated.

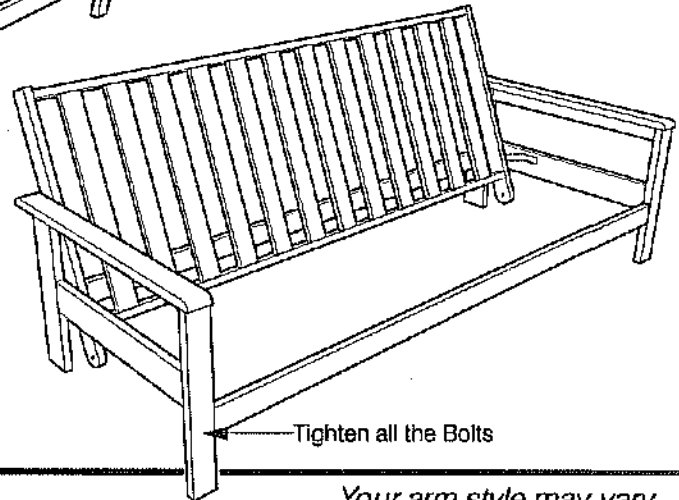

#### 4B Fit Seat Deck into Position.

*Your arm style may vary*

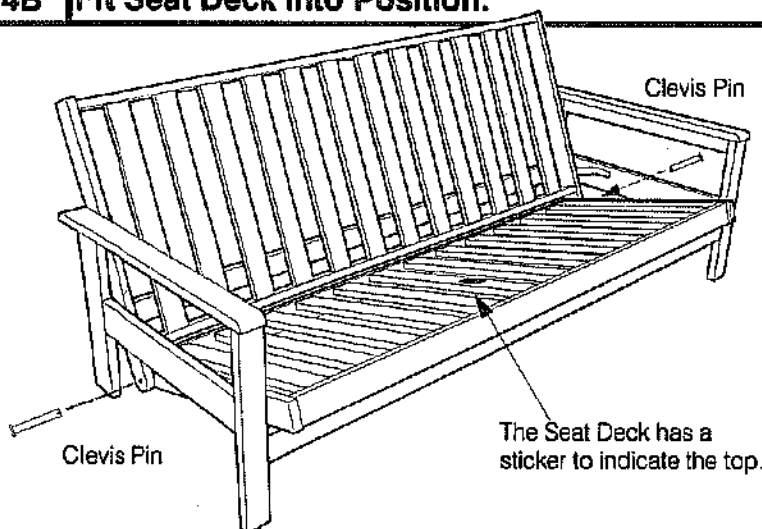

Fit the seat deck between the Arms and into the Back Deck as shown. Use the Clevis Pins to connect the two decks. Secure with a Washer and Locking Pin.

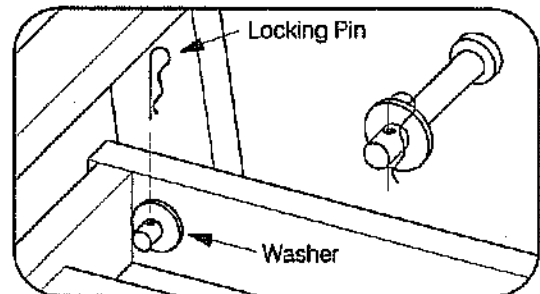

#### 4C For Queen size frame only: Attach short legs

*Your arm style may vary*

Using the extra 50mm bolts, attach the Queen short legs to the back deck.

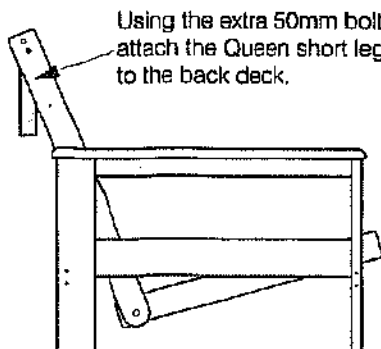

##### Important Note:

Orientation of the Queen Short Leg, note that the exposed part of the metal nut in the leg should be oriented away from the bolt for proper assembly.

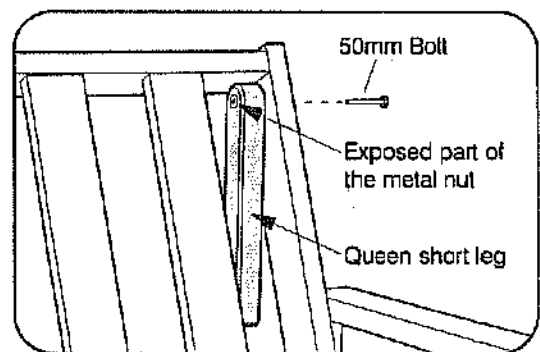



# OPERATING INSTRUCTION

## FUTON FRAME

# BIFOLD BODY

Instructions apply to all sizes:

Chair • Full / Double

Love seat • Queen

### 1 Assembled views

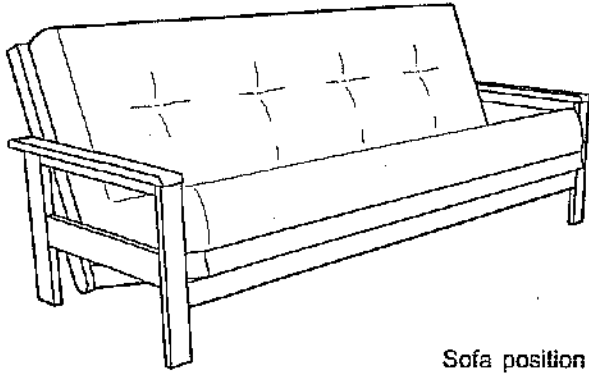

Sofa position

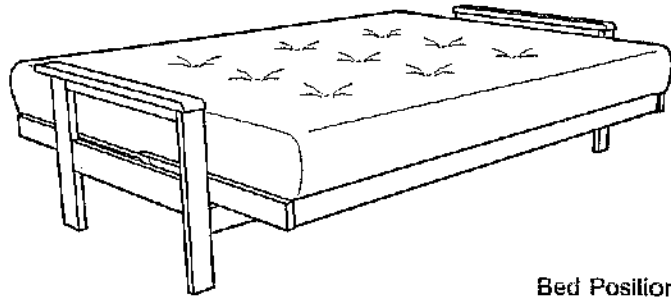

Bed Position

### 2 Sofa and Lounge to Bed Position

Your arm style may vary.

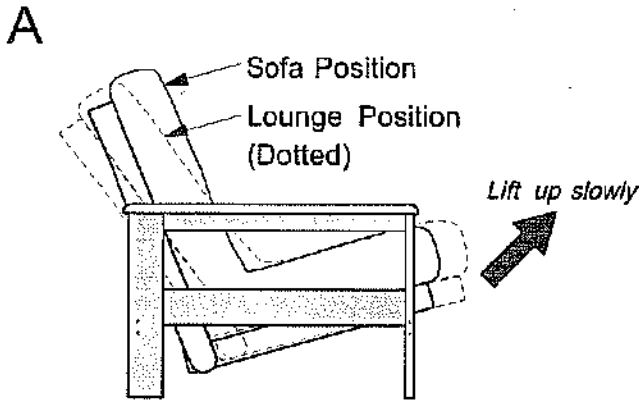

Pull up gently, and let the back drop down slowly.

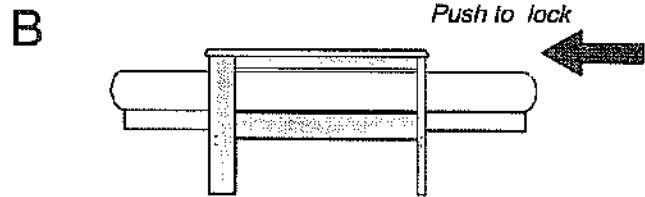

Lock in bed position.

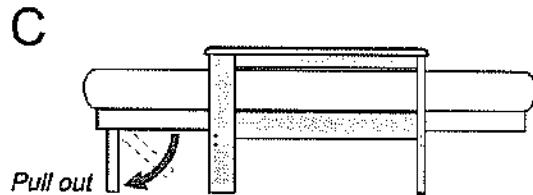

Queen size only:- Pull out the short legs.

### 3 Bed to Lounge Position

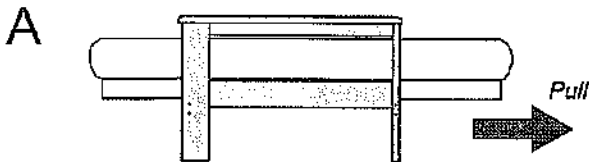

Pull out to unlock - Don't forget!

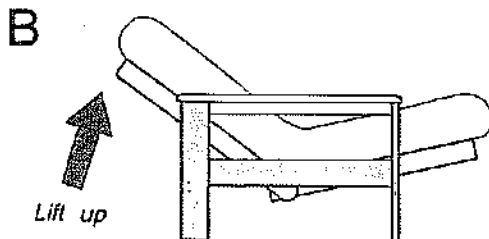

From the back: Lift up to lounge position.

### 4 Lounge to Sofa Position

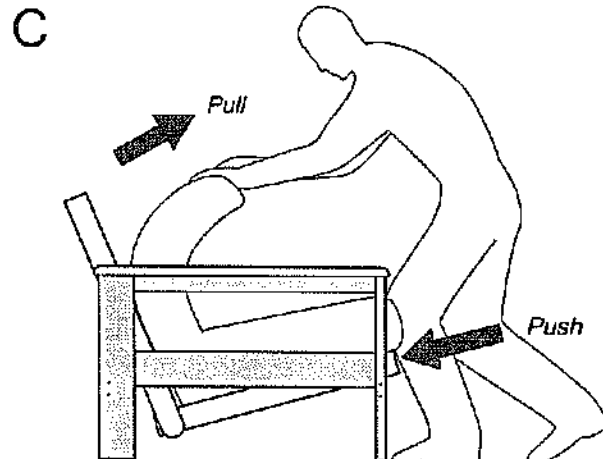

From the front: Pull back on the mattress and push into sofa position with your leg.