

## 1 Parts in this box:

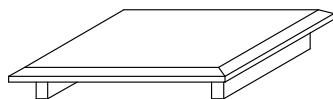
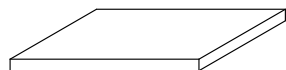
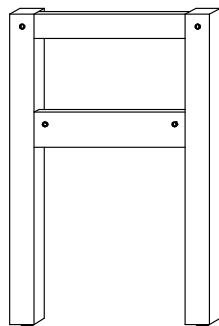

Table Top **x 1**



Shelf **x 1**



Leg Frame **x 1**



Wood Strip **x 1**

- Note: Only used with P-Series Beds

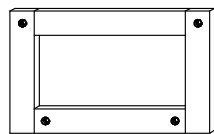

Inside Frame **x 1**

## 2 Hardware in this box:



80mm Bolts **x 2**

- to attach the Leg Frame



60mm Bolts **x 2**

- to attach the Inside Frame



30mm Bolts **x 4**

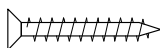

16mm Wood  
Screws **x 6**

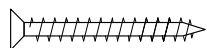

25mm Wood  
Screws **x 2**



Barrel Nuts **x 4**

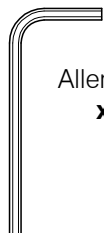

Allen Key  
**x 1**

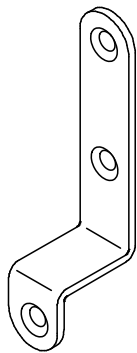

Metal Bracket  
**x 2**



Wood Buttons  
**x 6**

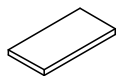

Felt Pad  
**x 2**

## 3 Assemble the Legs and Table Top:

Attach the Legs to the Table Top using the longer **80mm** bolts and barrel nuts. There is a **Wider space** on one side of the Table Top for the legs.

Attach the Inside Frame with **60mm** bolts and barrel Nuts. There is a **Narrower space** on one side for this.

Attach the shelf with the 30mm bolts.

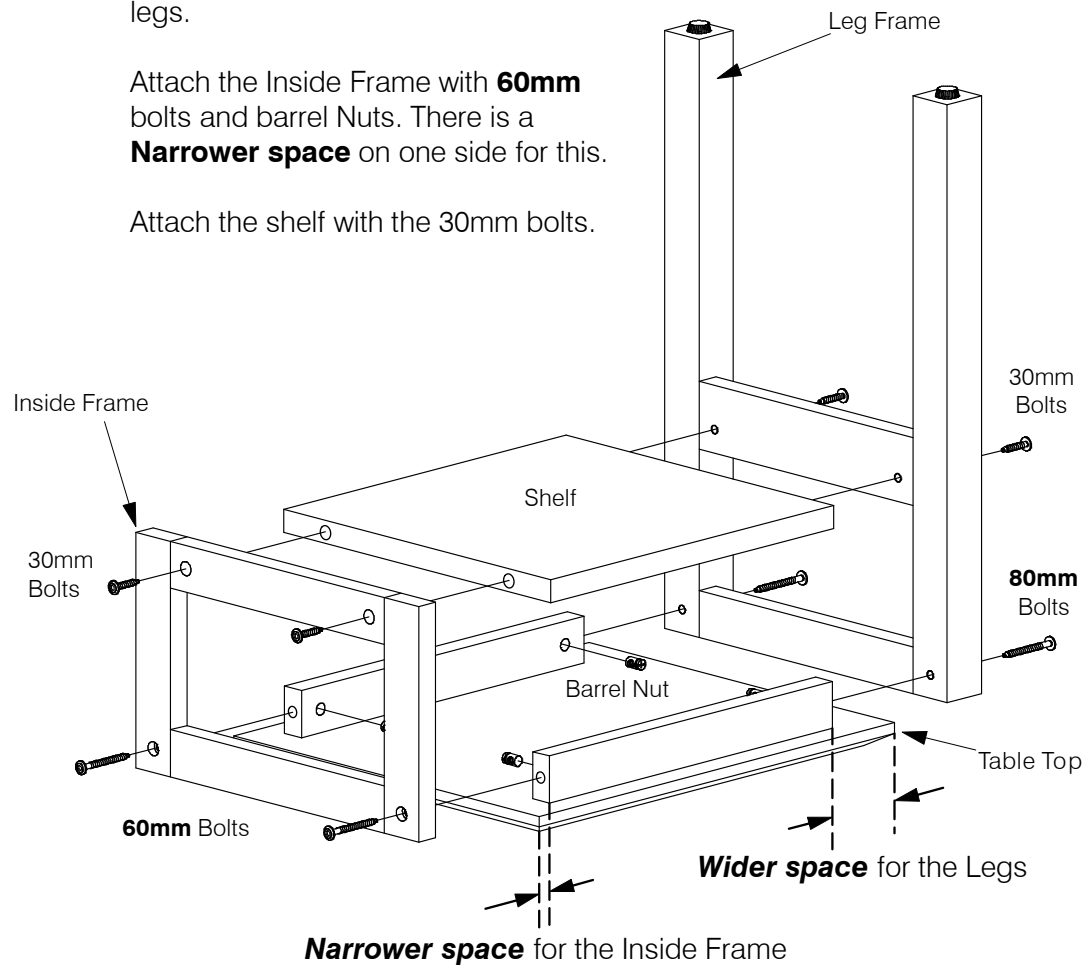

## 4 Assemble the Metal Brackets:

For Rails **13 1/2" high** (P-Series Beds) use the Bottom holes and screw the Wood Strip to the bottom of the Inside Frame.

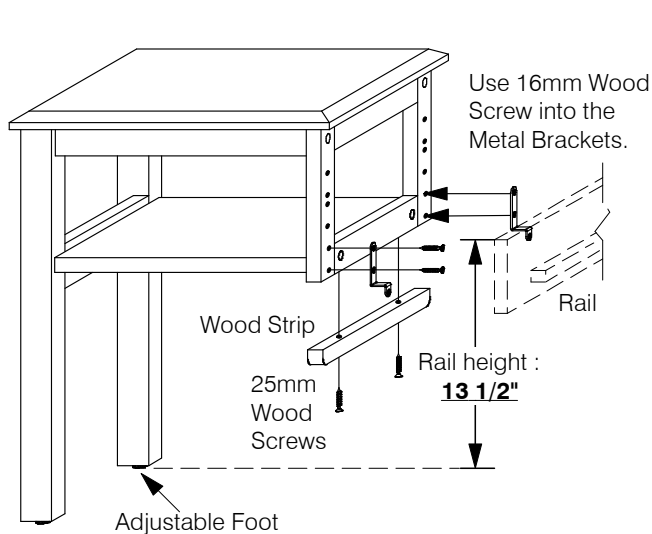

For Rails **16 1/4" high** (K-Series Beds) use the Center holes.

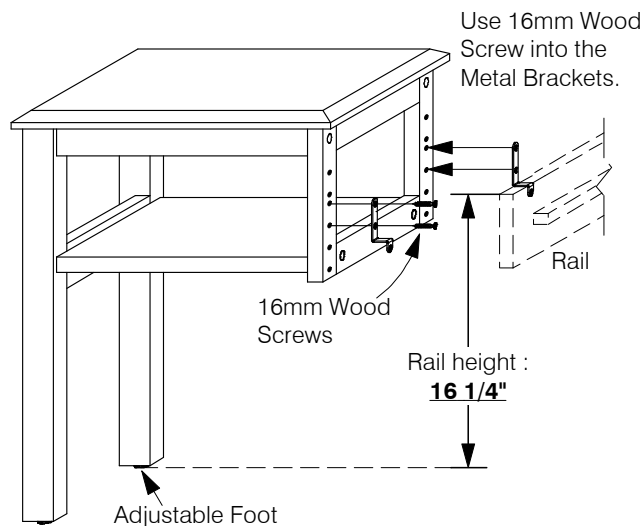

For Rails **17 3/4" high** use the Upper holes.

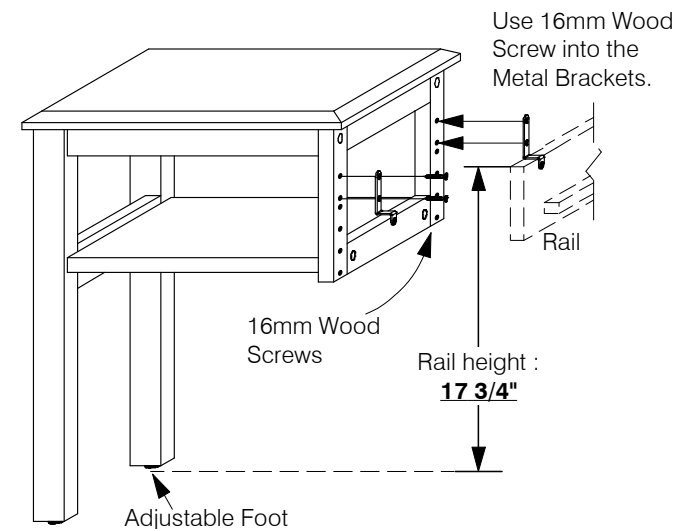

## 5 Fit onto the Bed rails.

The Hook-on Nightstand screws onto the bed rail with 16mm woodscrews.

Finally, fit wood buttons over the bolt holes as shown here.

Apply the Felt Pad to the Bottom of the Bracket to protect the Bed Rail.

